

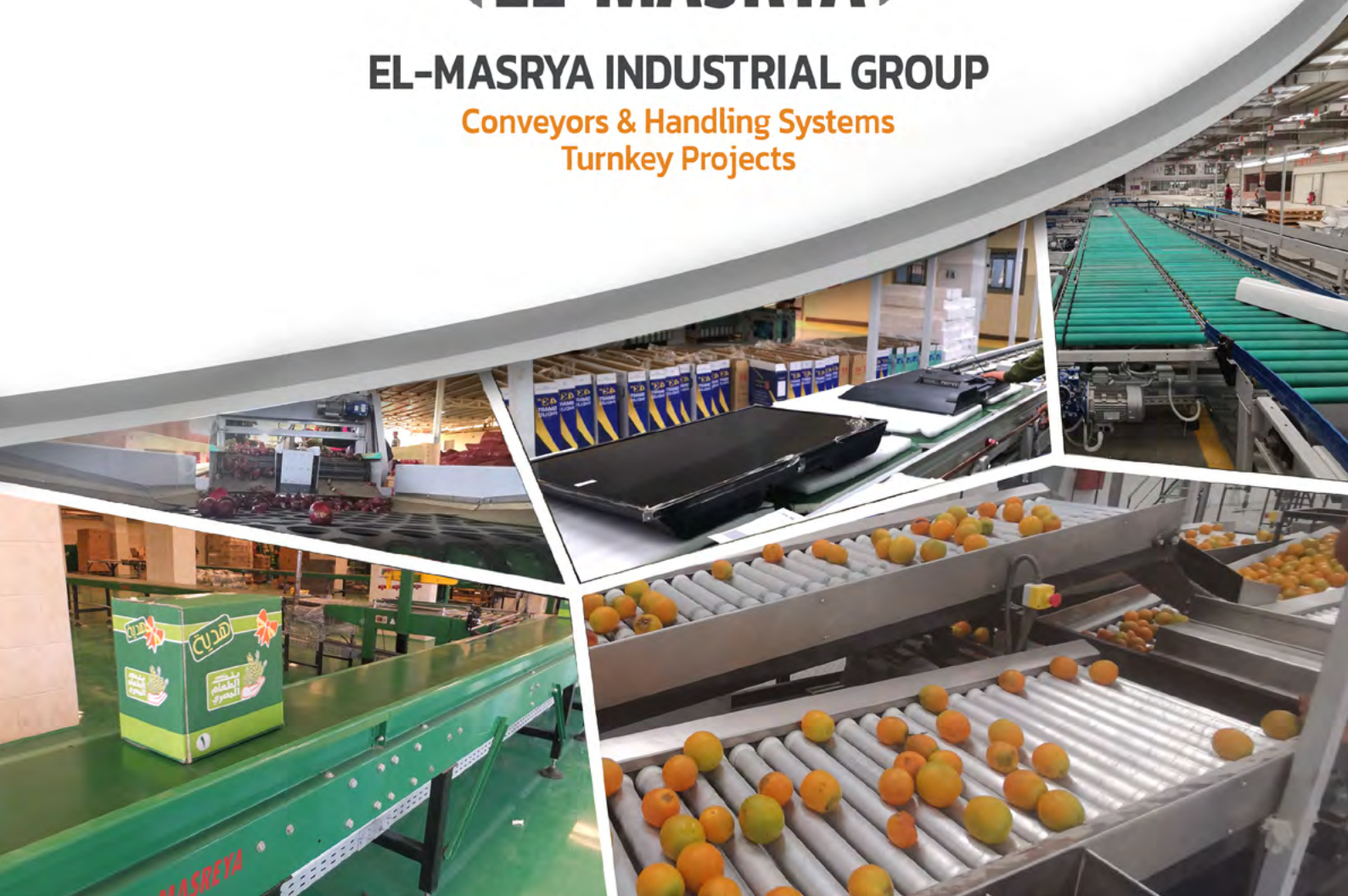

EL-MASRYA INDUSTRIAL GROUP

**Conveyors & Handling Systems
Turnkey Projects**



About Us

El-Masrya Industrial Group is an Egyptian company established in 2001 as leading company that specialized in manufacturing and innovating handling solutions to the industrial Egyptian market & Middle East.

El-Masrya Industrial Group contributes to

- 1- Organization of production area to raising efficiency
- 2- Reduce the effort of handling
- 3- The maximum space utilization
- 4- Easy of loading and unloading



- In manufacturing, we rely on the following CNC machines (Centrelathe, Folding, Punching and waterjet).
- In design, we rely on professional 2D and 3D drawing programs (AutoCAD and Solidworks).
- In management, we rely on Total Quality Managment system.
- In production, we rely on food hygiene standards.

Major Projects

- System Integration.
- Home appliances assembly lines.
- Poultry slaughter lines of various production capacities.
- Eggs sorting, cleaning and packing lines.
- Fish and shrimp cleaning, packaging and sizing lines.
- Lines for sorting, sizing and packing citrus, grapes and mangoes.
- Onion sorting, sizing and packing lines.
- Various food production and packaging lines.
- Sanitary ware sorting and inspection lines.
- Tuna filling lines.
- Live poultry transport lines.

Home Appliances Assembly Lines

The purpose of home appliance assembly lines

Facilitating the assembly process that takes place on electrical appliances (TV - air conditioner - Refrigerator - Washing machine - microwave, etc.) through the circulation of raw materials between workers without the need for manual handling, which increases production and quality.

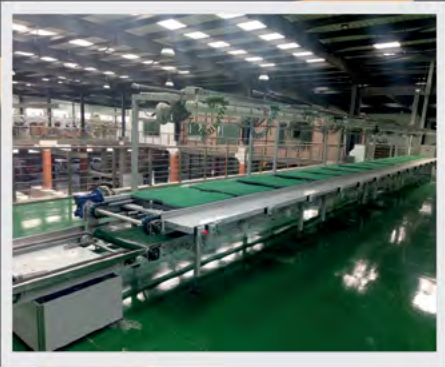

- Screen assembly and testing lines of all sizes

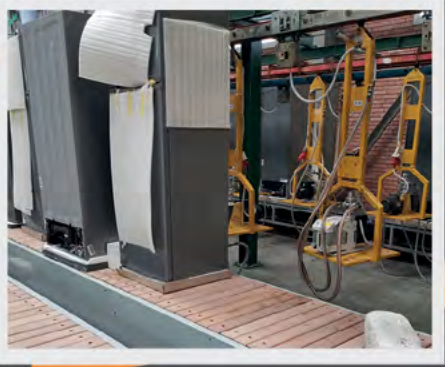

- Assembly and testing lines for refrigerators, washing machines and deep freezers

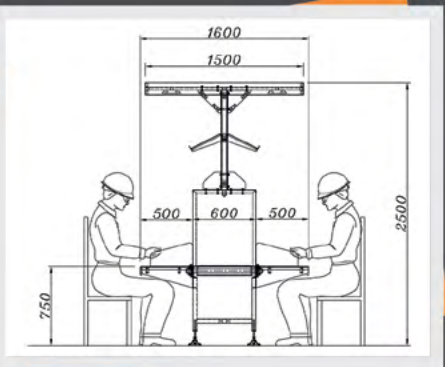

- Small home appliances assembly and testing lines



Poultry Slaughter

For Exporting to MENA

The purpose of the line, we produce poultry slaughterhouse equipment in addition to the slaughterhouse waste treatment unit. The technical office of the company provides the necessary technical consultations for the establishment of semi-automatic and automated poultrytt slaughterhouses. The company undertakes the production of all semi-automated slaughterhouse equipment and also completes it to automated slaughterhouses in cooperation with European companies to supply Evisceration machines and scales.

The most important types of massacres are as follows:
Expandable slaughterhouse from 300 to 3000 birds per hour

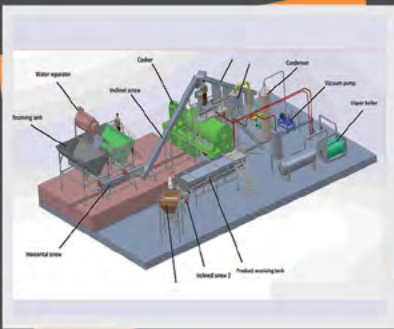

Rendering Plant



Weighing Line



Junior 500 b/h

Egg Sorting Lines

The purpose of the line is to have a clean, high quality product stamped with today's date without any intervention from workers.

The line begins with eggs entering the stage of visual inspection to confirm the quality of the eggs from outside and inside, and then the stage of washing and drying then stamping the eggs with today's date to let the consumer make sure of their validation.

And finally, the stage of packaging and transporting them to the consumer as a premium-quality product.



Fish and shrimp cleaning and packaging line

The purpose of the line Facilitating the process of handling fish inside the production hall, where the fish are cleaned of blood, washed, then cleaned from the head and entrails, and then prepared to be finished products. For shrimp, clean the shrimp from the sand, and then sort the shrimp into 6 different sizes.

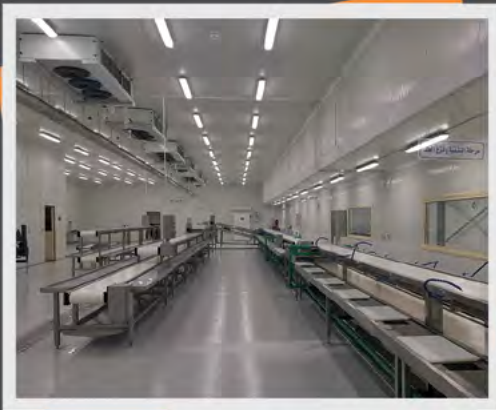

Sorting and washing process:

The fish or shrimps are placed in wash basins with ice to keep the products cool, then the products are transported with an ascending belt to filter the products from the water in trays and drain the waste water.



The process of cleaning and removing the skin:

The stages of cleaning fish start from the guts and head, then remove the skin with a skin removal machine, then enter the products to remove the thorns.

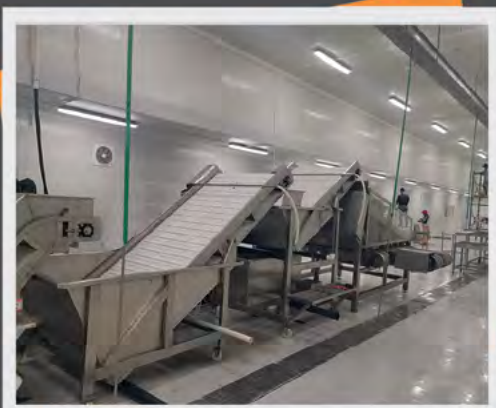

Sterilization by ozone, weighing, packing and freezing:

Sterilization of the products in the ozone machine, then the products are weighed and placed in bags according to the weight, and the bags are placed in the vacuum machine, then the products are frozen.

Shrimp size:

Shrimp are sorted into 6 different sizes after washing and cleaning, and then they are frozen.

Citrus, Grape and Mango Sorting Lines

Conveyor system suitable for different types of agricultural crops

Where agricultural crops of all kinds are entered into several stages that include:

The washing stage, the waxing stage, the sorting and sizing stage, and finally the packing stage. In the grape line, examination and weighing are carried out on tables designated for these products.

The empty cartons can be fed with nozzles on top of the lines or with a movable monorail to cover all the tables.

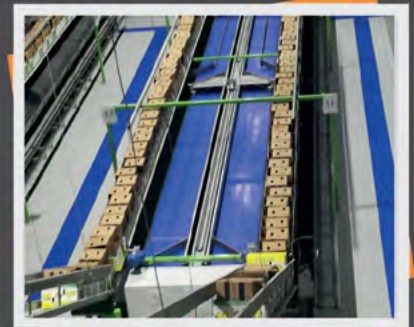
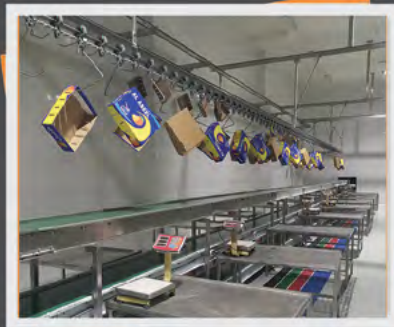

Onion Sorting Lines

The purpose of onion sorting lines

It consists of several stages, namely line feeding, visual sorting, sizing, and then packing.

- Visual sorting of the onions and separating the premium ones from the unacceptable sort.
- Resize the onions in terms of sizes upon request (up to 10 sizes can be made).
- Separate packing for each volume with weight adjustment using scales for each outlet.



Food Production and Packaging Lines

Multipurpose conveyor system includes conveyors under the packing machines that collect the bags of products and collect them on the packing belt conveyors themselves, where the workers collect them in cartons and then transfer the cartons to the warehouse or loaded into the container through a telescopic conveyor.



Sanitary ware Sorting Lines

The first line for sorting and testing sanitary ware is manufactured in Egypt Contributed to a significant increase in the rate of production and also reduce the effort spent in transporting the product in each step of the sorting process, which led to reduce the risks of product breaking during the inspection and handling process.



Spiral Conveyor

Save Space And Dynamic Buffering
Suitable For Bakery Industry

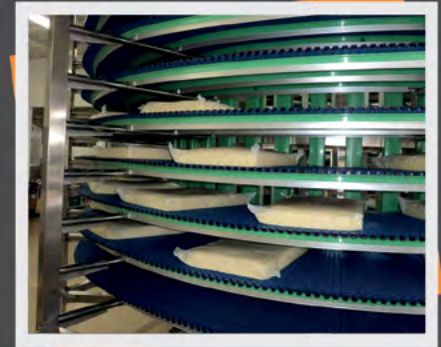

Checkweigher System

Simple, customized and easy to export the required data
Suitable For Food, Packing and Chemical Industries



Lid Press Conveyor

A handling solution that helps continuous seal paint containers automatically to save time of the production process in the chemical and paint industries.

Simple, durable, saving time and easy to install
Suitable For Paints and Chemical Industries



Belt Conveyor

PVC and PU Belts

Inexpensive, Simple, Quiet and easy to install

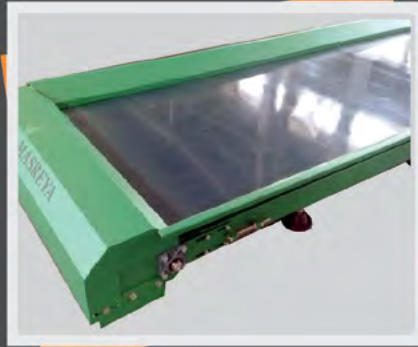

Suitable For Food, beverage, pharmaceutical and chemical Industries

Free and Motorized Rollers Conveyor

Versatile, simple and inexpensive

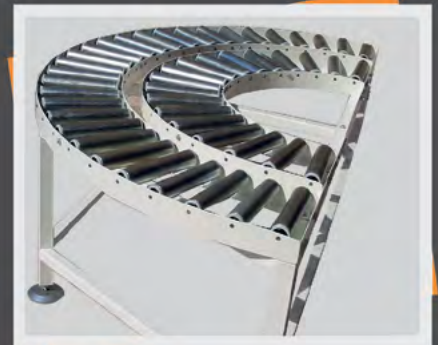
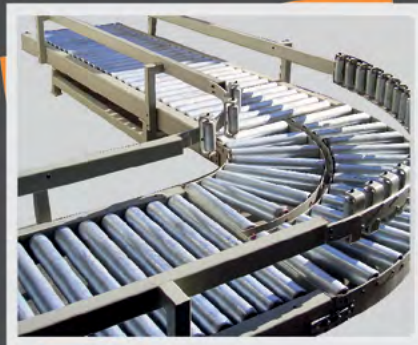
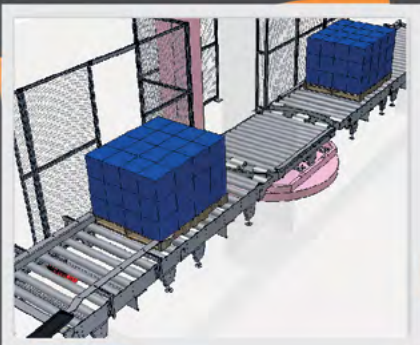

Suitable For Food, beverage, pharmaceutical and chemical Industries

Loading Conveyor

Adjustable length and height
Heavy duty and continuous operation

Suitable For Cement, Fertilizers and Chemical Industries



Chain Conveyor



Inexpensive, Easy maintenance and available with different shapes (45° and 90°) in different materials (Plastic and St. St304)

Suitable For Food, beverage, pharmaceutical and chemical Industries

Modular belt Conveyor



Versatile, easy to clean, suitable for hot and cold products and quiet running
Suitable For Food, beverage, snacks and chemical Industries

Rotating Turntable

Simple, Quiet and inexpensive

Suitable For Food, beverage, pharmaceutical and Snacks Industries



Vertical & Gripper Conveyors



Wood & Steel Belt Conveyor

Heavy duty, assembly lines and production operations



Importing Countries



Our Success Partners



6th Industrial Zone - 6 October City, Giza, Egypt
 +20 102 333 6579 | +20 106 334 0110
 +20 239 123 526
 sales@el-masrya.com
 www.el-masrya.com

